

NO.	QTY.	DESCRIPTION	MODEL NUMBER			STANDARD SEAL KIT	FLUOROCARBON SEAL KIT
			14-0205-01-X-PS	14-0209-01-X-PS	14-0213-01-X-PS		
1	1	BUTTON HEAD CAP SCREW	21-4110-01	21-4100-09	21-4100-39	NO	NO
2	1	WIPER, ROD (FLUOROCARBON)	39-0530-04	39-0530-01	39-0530-00	YES	YES
3	1	BACK-UP RING, ROD	39-F540-00	39-F540-01	39-F540-02	YES	YES
4	1	SEAL, ROD (STANDARD)	39-0100-38	39-0100-20	39-0110-46	YES	NO
	1	SEAL, ROD (FLUOROCARBON)	39-0520-14	39-V100-20	39-V110-46	NO	YES
5	3	BALL, STEEL ALLOY	23-6000-14	23-6000-11	23-6000-02	YES	YES
6	3	BALL SEAT ASSEMBLY	90-1999-56	90-1999-57	90-1999-58	YES	YES
7	1	PLUNGER, LEFT HAND (SHOWN)	81-4000-50	81-4000-51	81-4000-52	NO	NO
	1	PLUNGER, RIGHT HAND	81-4000-47	81-4000-48	81-4000-49	NO	NO
8	1	SEAL, PLUNGER (STANDARD)	39-H100-37	39-H100-18	39-H110-30	YES	NO
	1	SEAL, PLUNGER (FLUOROCARBON)	39-V100-37	39-V100-18	39-V110-30	NO	YES
9	1	STEM	81-5000-10	81-5000-11	81-5000-12	NO	NO
10	1	MAGNET	91-1000-01	91-1000-01	91-1000-01	NO	NO
11	1	BUTTON HEAD CAP SCREW	21-4100-61	21-4100-61	21-4100-61	NO	NO
12	1	O-RING, RETAINER (FLUOROCARBON)	39-V000-36	39-0510-31	39-V510-43	YES	YES
13	1	RETAINER	81-4000-44	81-4000-45	81-4000-46	NO	NO
N/A	N/A	SEAL KIT (STANDARD)	60-1400-27	60-1400-28	60-1400-22	INCLUDED IN KIT	
N/A	N/A	SEAL KIT (FLUOROCARBON)	6V-1400-27	6V-1400-28	6V-1400-22		

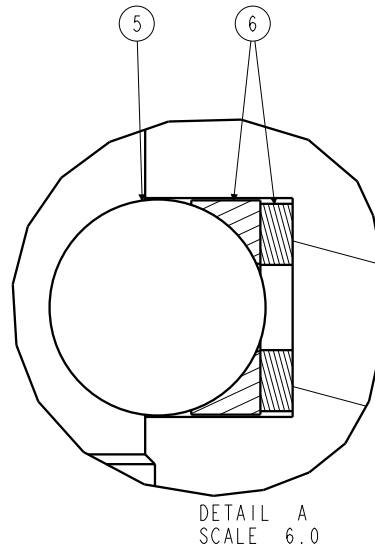

Lubricate all seals with clean hydraulic fluid prior to assembly.

**PARTS LIST**

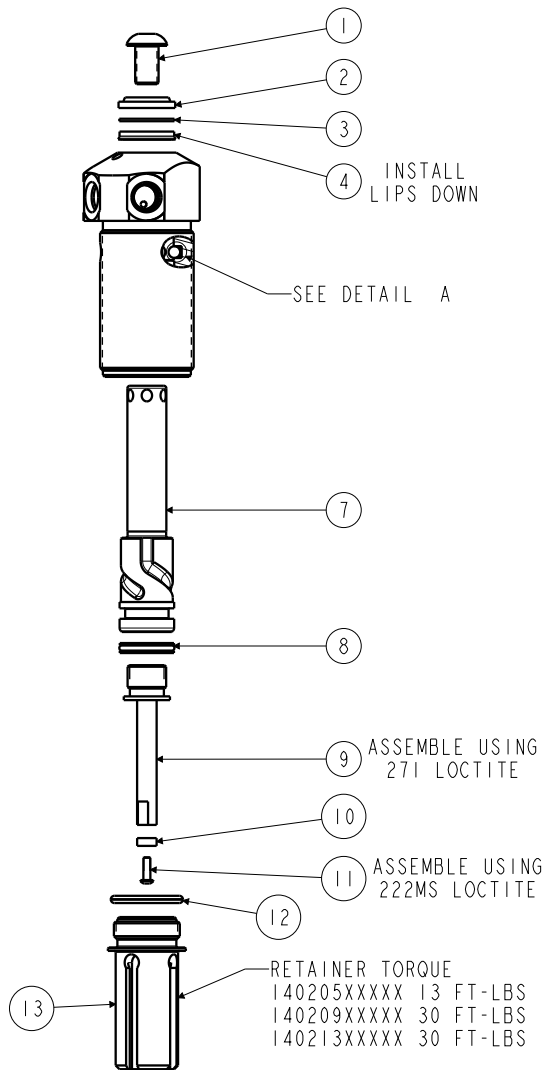

VEKTEK, INC.  
 1334 E. SIXTH AVE. P.O. BOX 625  
 EMPORIA, KS. 66801 U.S.A.

ASSEMBLIES AFFECTED  
 14-0205-01-L-PS, 14-0205-01-L-F-PS  
 14-0205-01-R-PS, 14-0205-01-R-F-PS  
 14-0209-01-L-PS, 14-0209-01-L-F-PS  
 14-0209-01-R-PS, 14-0209-01-R-F-PS  
 14-0213-01-L-PS, 14-0213-01-L-F-PS  
 14-0213-01-R-PS, 14-0213-01-R-F-PS

PARTS LIST, SC, TB, HS, DA, PS

SIZE A P11417

REV F

SHEET 1 OF 1